

PROFESSIONAL ROLL FORMING MACHINE

MANUFACTURER

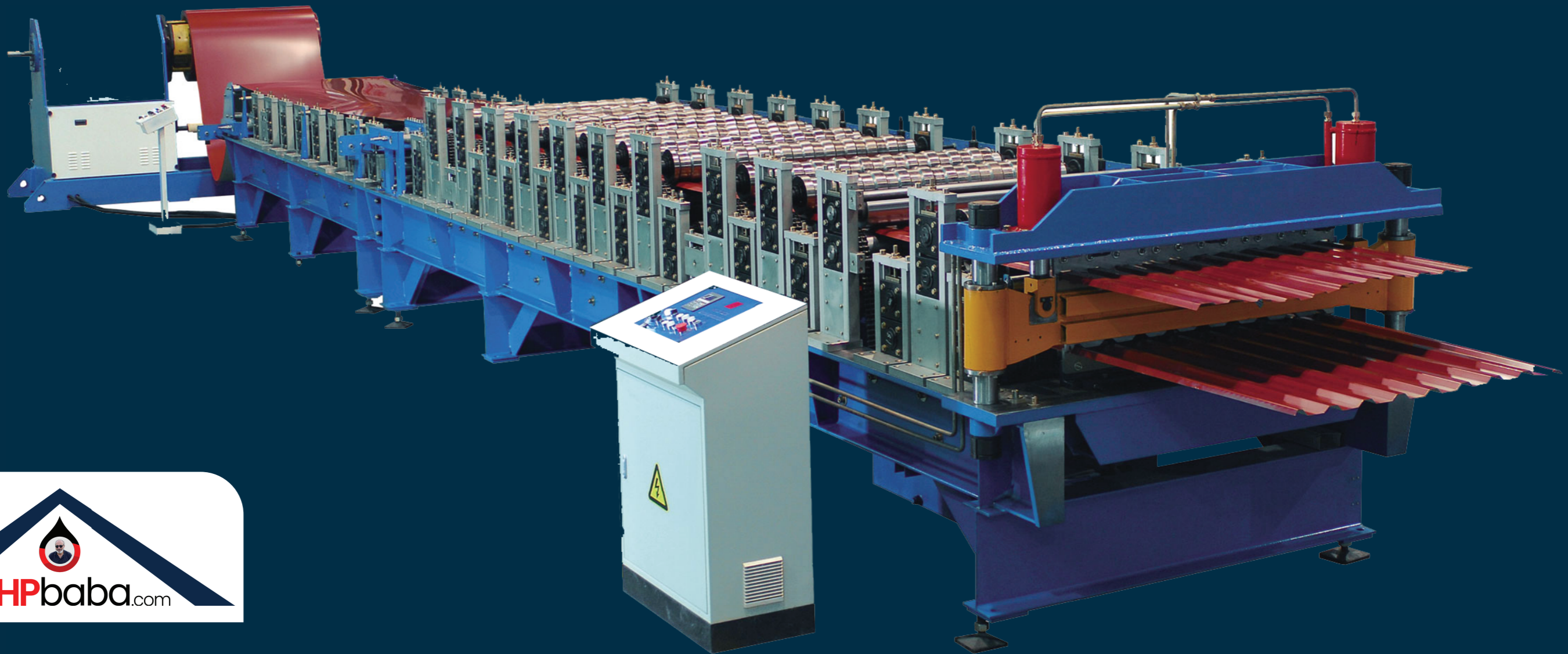

China Office:
+86-15501571292 - info@ahpbaba.com - www.ahpbaba.com
B2-1910, Zhengkai Wanda Plaza, Wuhan, China.

USA Office:
+1 2147151010 - imran@ahpbaba.com - www.ahpbaba.com
13151 Emily rd # 100 Dallas TX 75240 - USA.

- INTEGRITY
- QUALITY
- SCIENCE
- TECHNOLOGY

INTRODUCTION



AHPBaba is a China based sourcing and export company providing complete A-Z service for global buyers.

We help customers find reliable factories, negotiate the best prices, ensure high quality, and ship products worldwide.

INTEGRITY

QUALITY

SCIENCE

TECHNOLOGY



Quality and Professional After-sale Service have always been the core concept of our company's development. May our machines and efforts bring you successful for your business.



We provide a wide range of roll forming machines, including storage rack /shelf systems, door frames/ Roller shutter systems, metal ceiling systems, roofing systems, light steel/drywall systems, tube roll forming machine and many other customized profiles roll forming machines.



WORKING FLOW

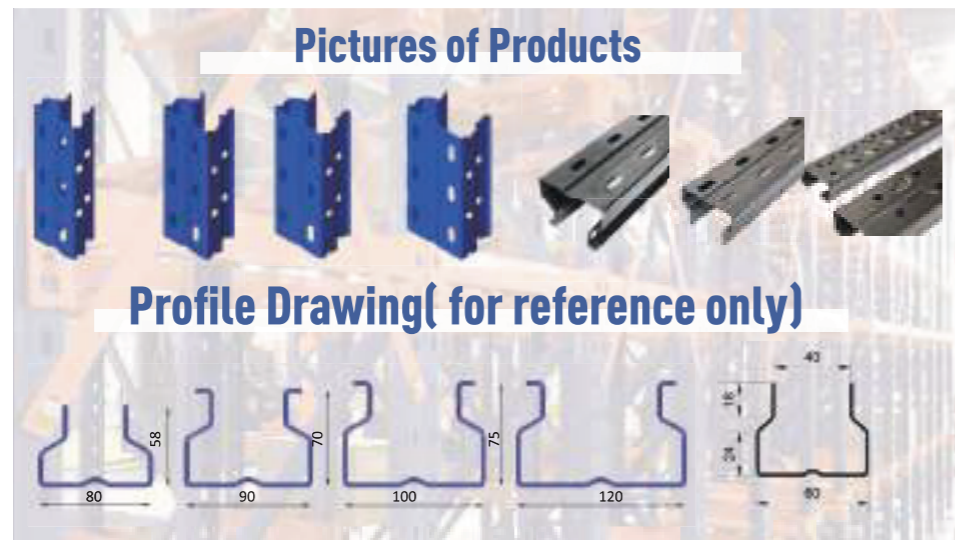
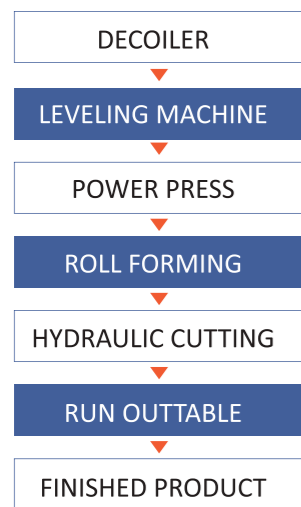

Layout of the stainless tube roll forming machine

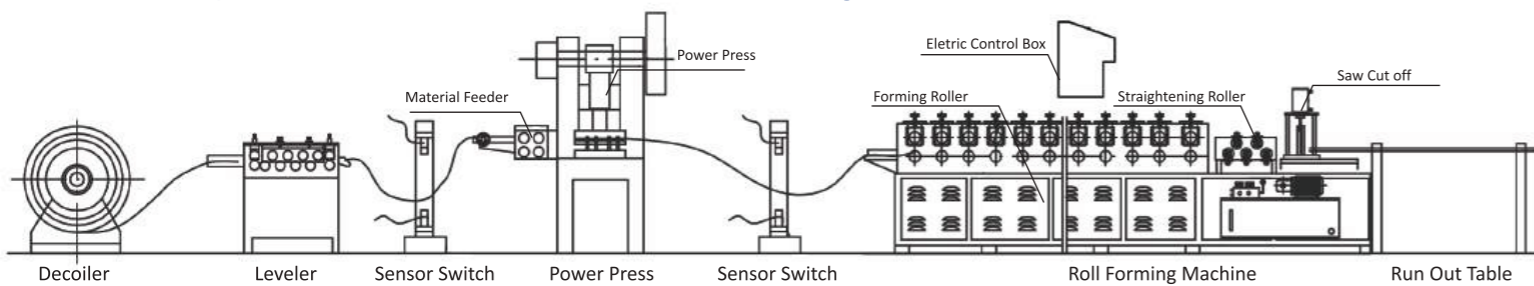

WORKING FLOW



Pictures of Products



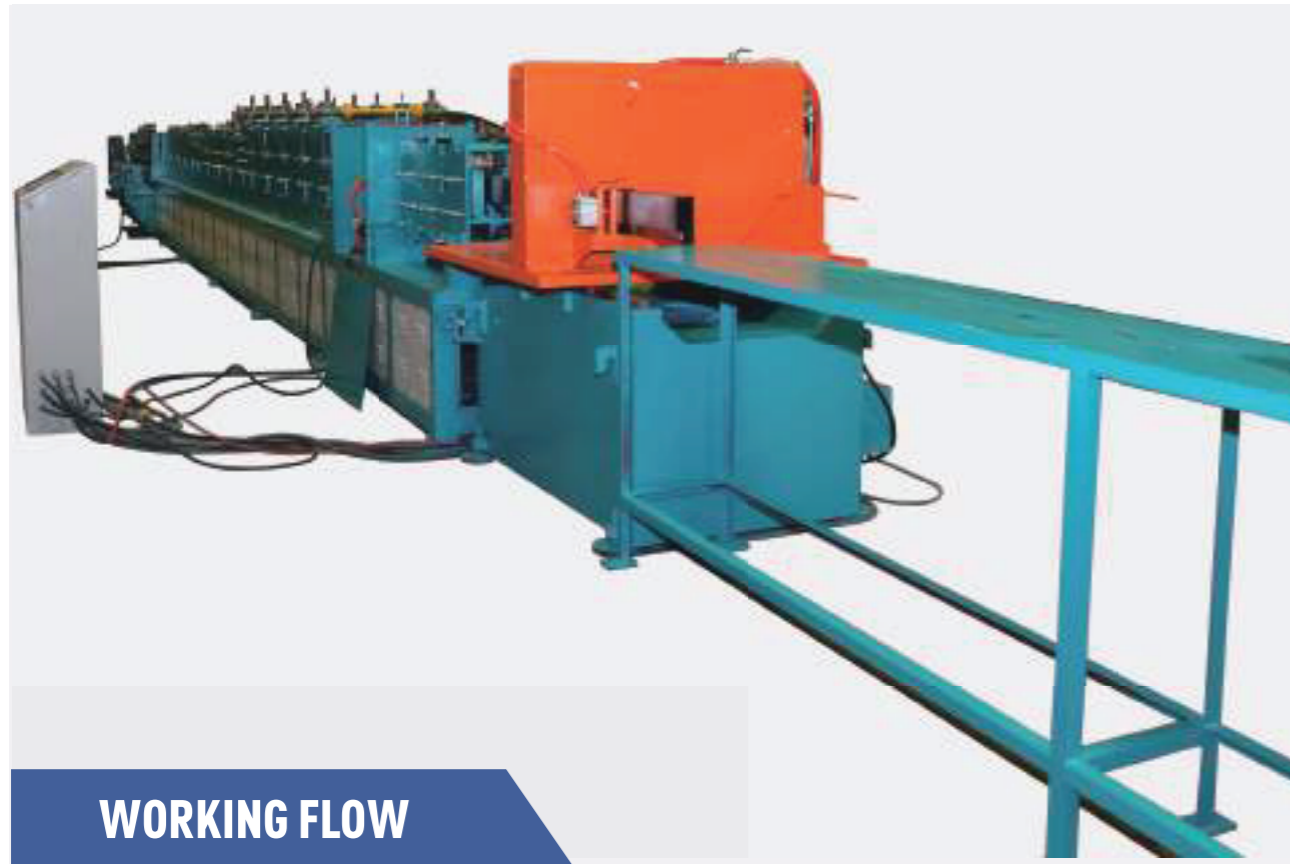

WORKING FLOW



Pictures of Products



Profile Drawing(for reference only)

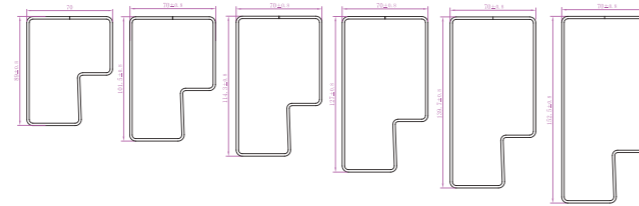

Layout of roll forming machine

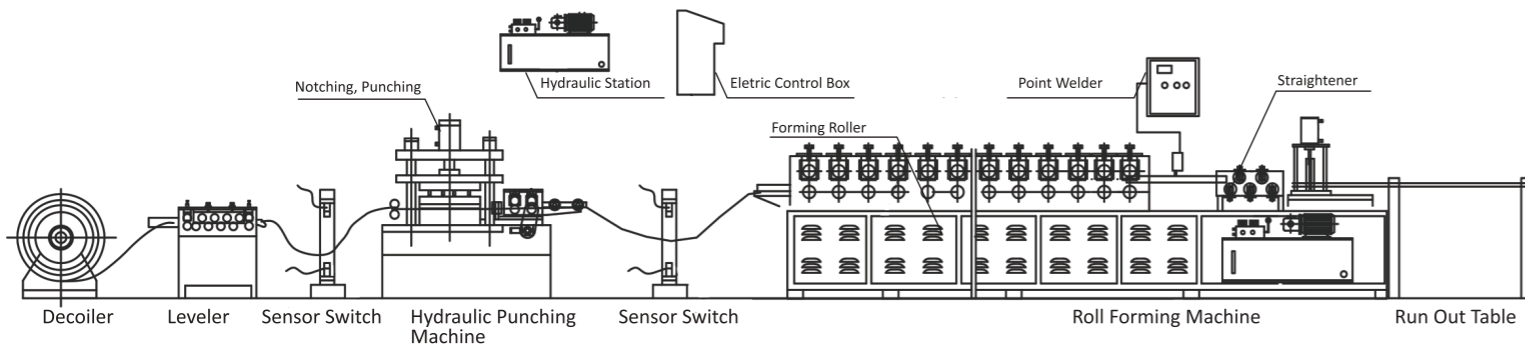

WORKING FLOW



Pictures of Products

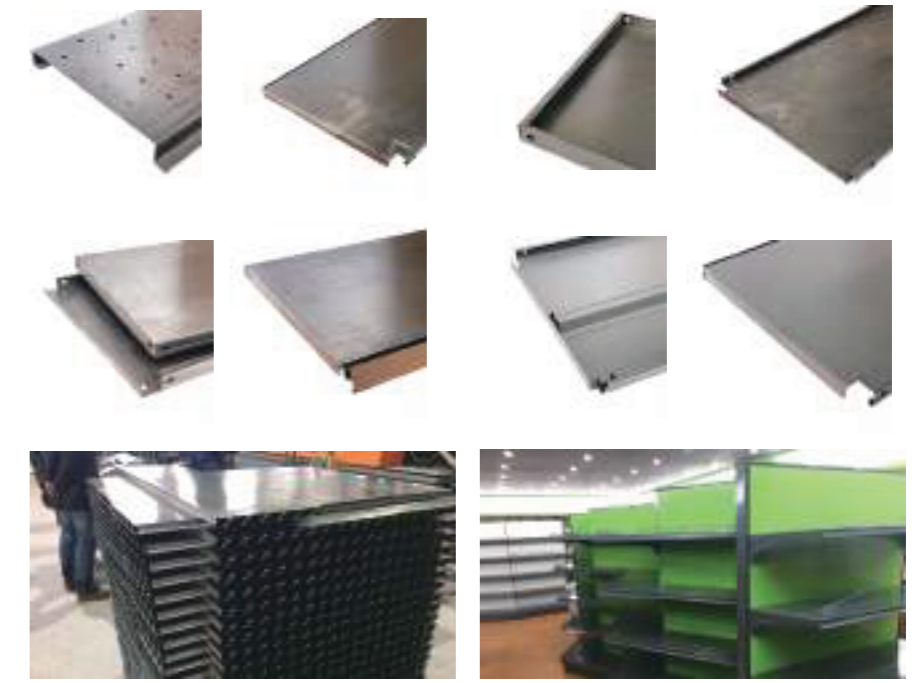



Pictures of Products

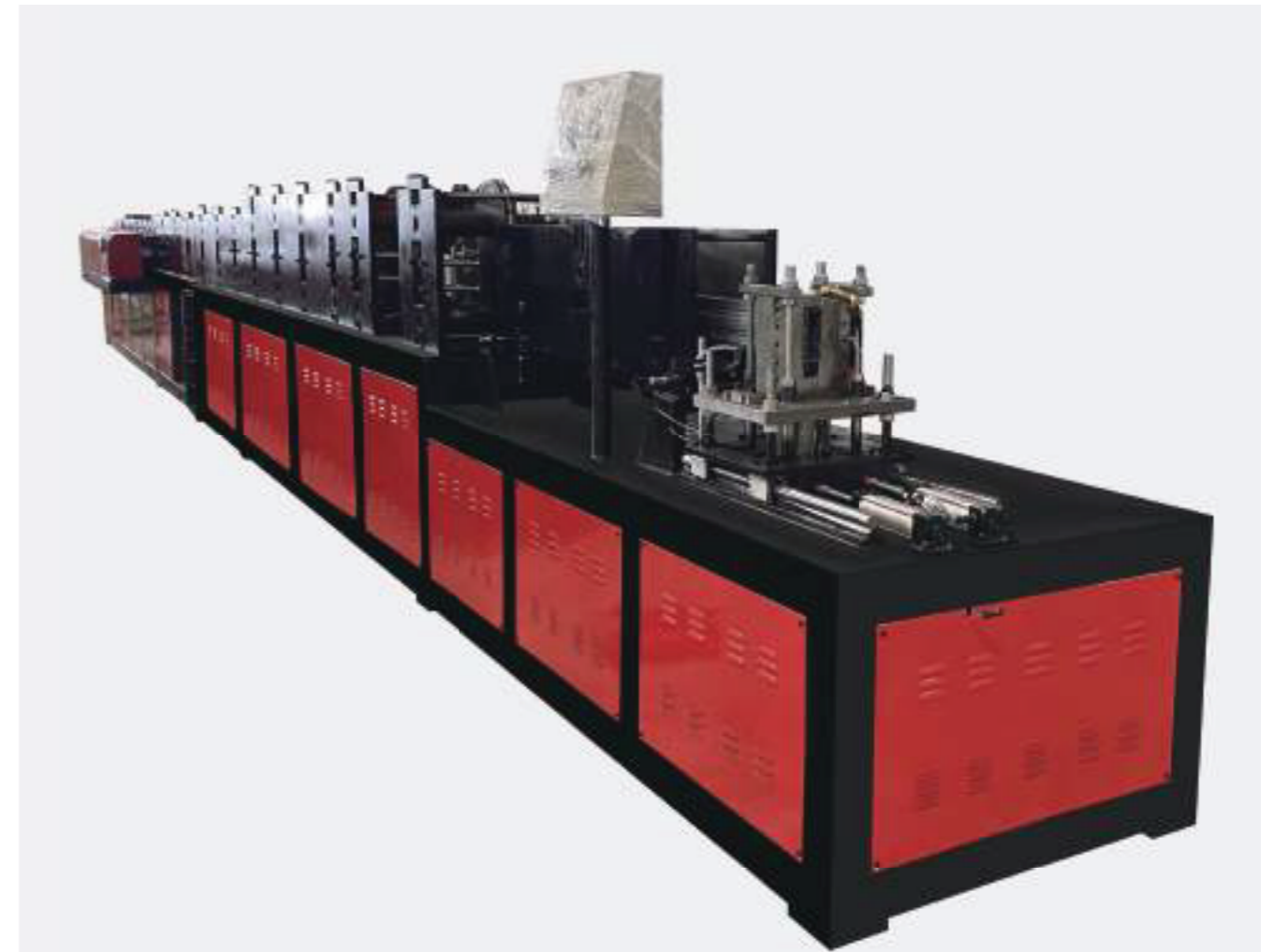

Pictures of Products





Pictures of Products



Layout of the upright rack roll forming machine

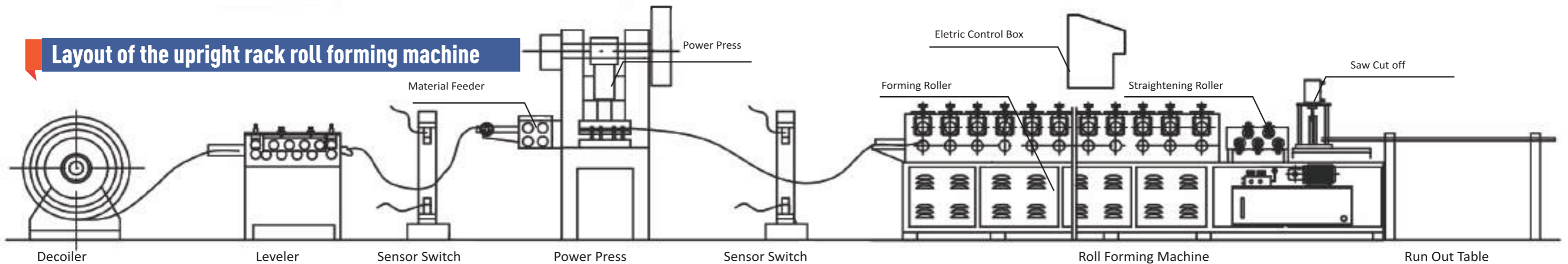

WORKING FLOW

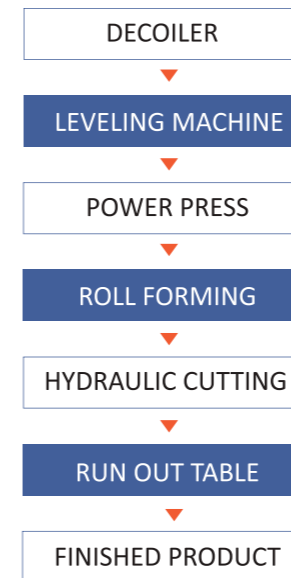

Pictures of Products



Profile Drawing (for reference only)

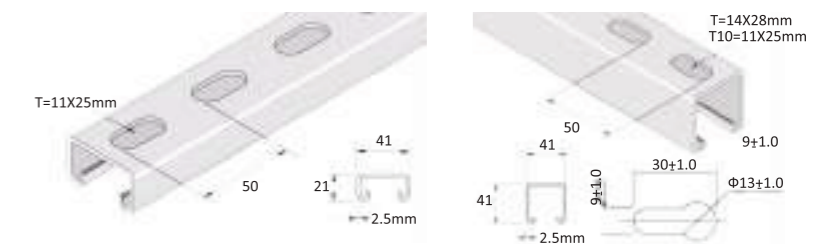

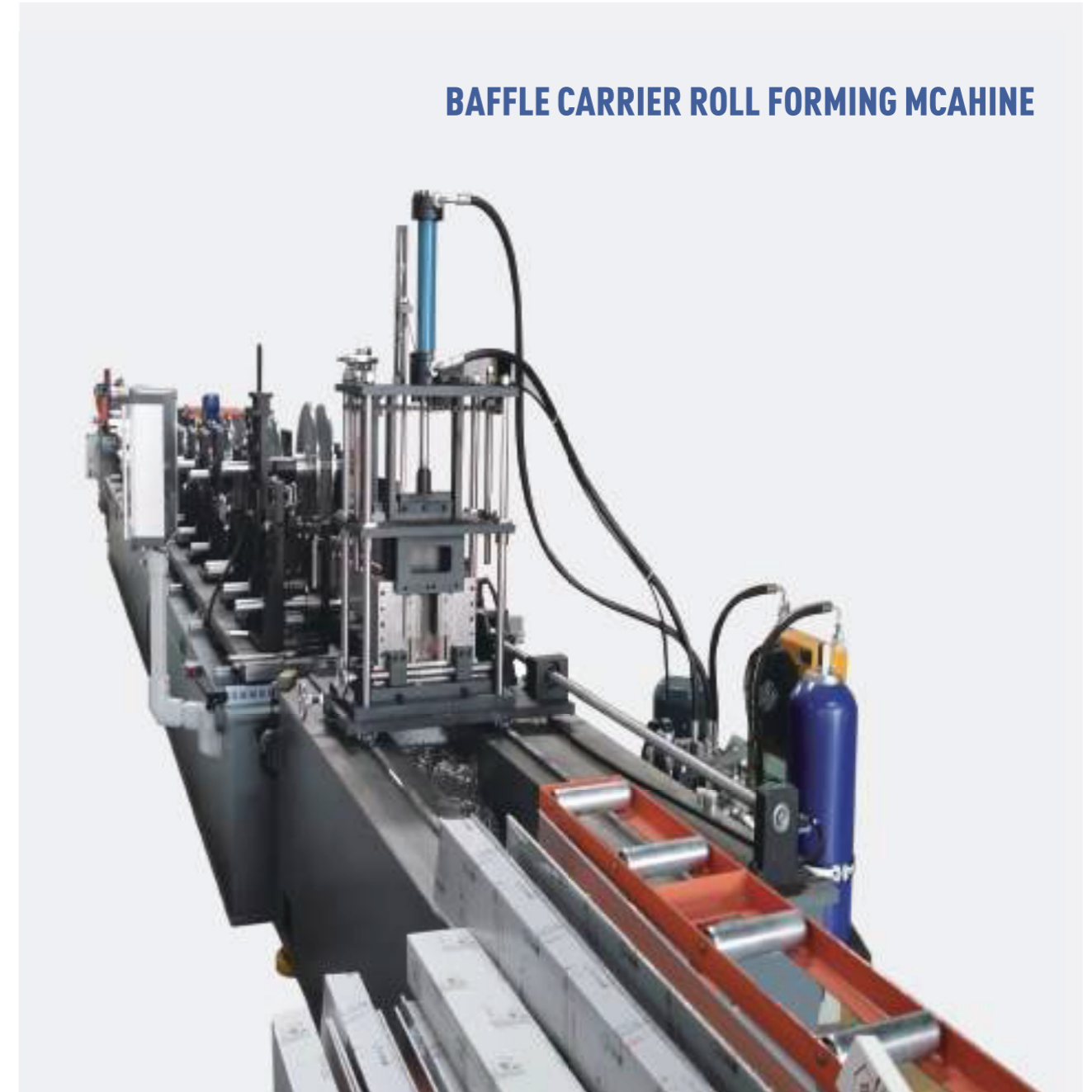

BAFFLE CARRIER ROLL FORMING MACHINE

WORKING FLOW

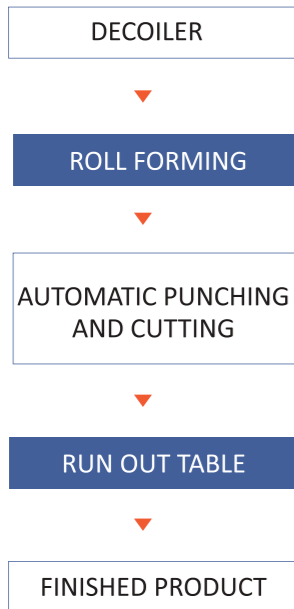

Pictures of Products



Pictures of Products





WORKING FLOW



Pictures of Products

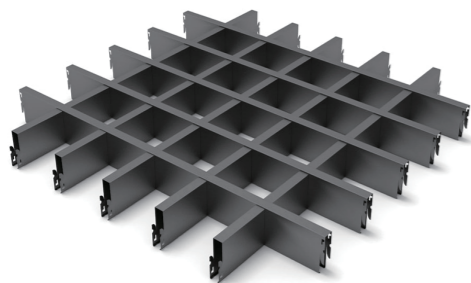

Pictures of Products



Punching die

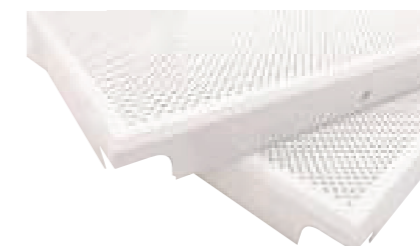

Clip in



Lay on



Pictures of Products

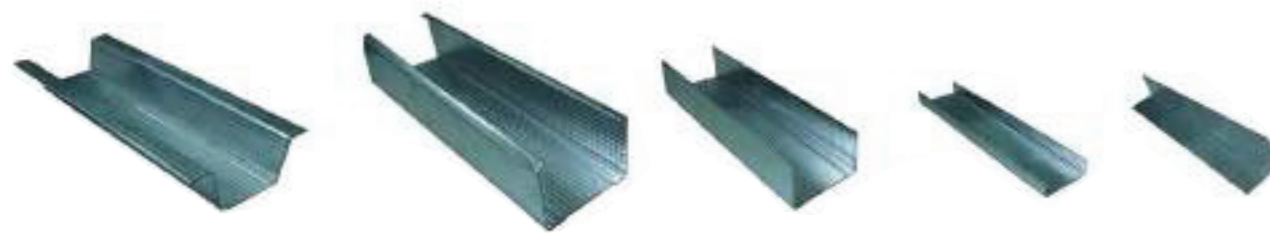

Profile Drawing(for reference only)



High speed, medium speed and normal speed are available.
The high speed type, maximum speed could be up to 120/min, flying cutting.
Protective cover is optional.



Pictures of Products



This machine is fully automatic manufacturing the metal stud/track/furring, from decoiler, roll forming machine, cut off and automatic packing. Which can save labor and improve production efficiency, working speed up to 100m/min. Customized sizes are available.

WORKING FLOW

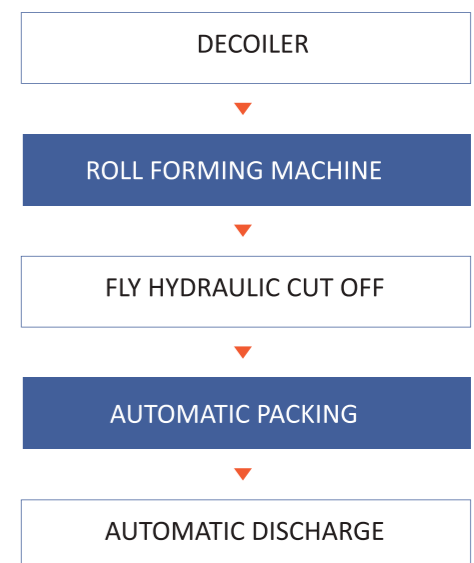



Profile Drawing(for reference only)

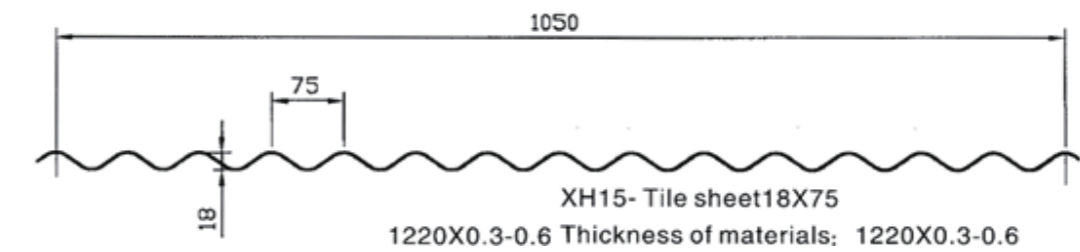
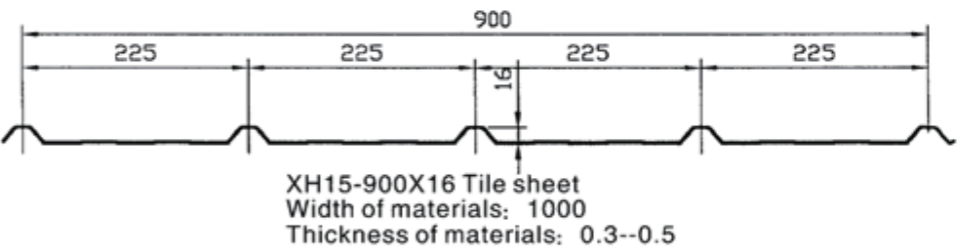
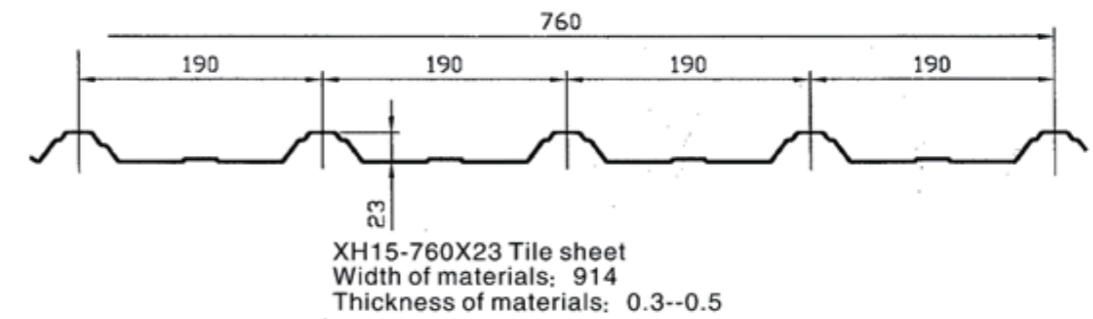
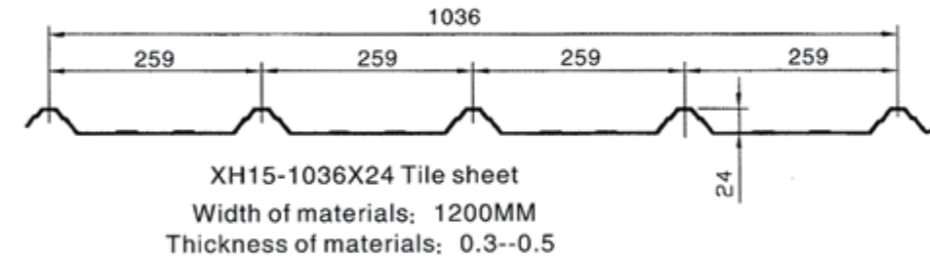
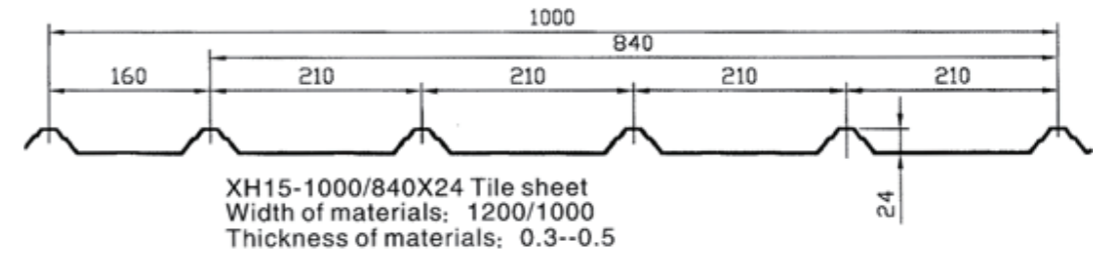
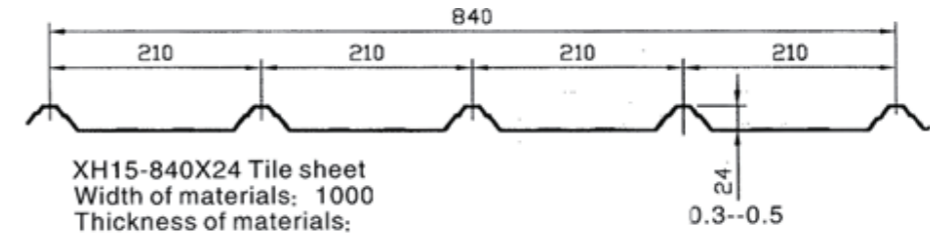

Pictures of Products





Pictures of Products

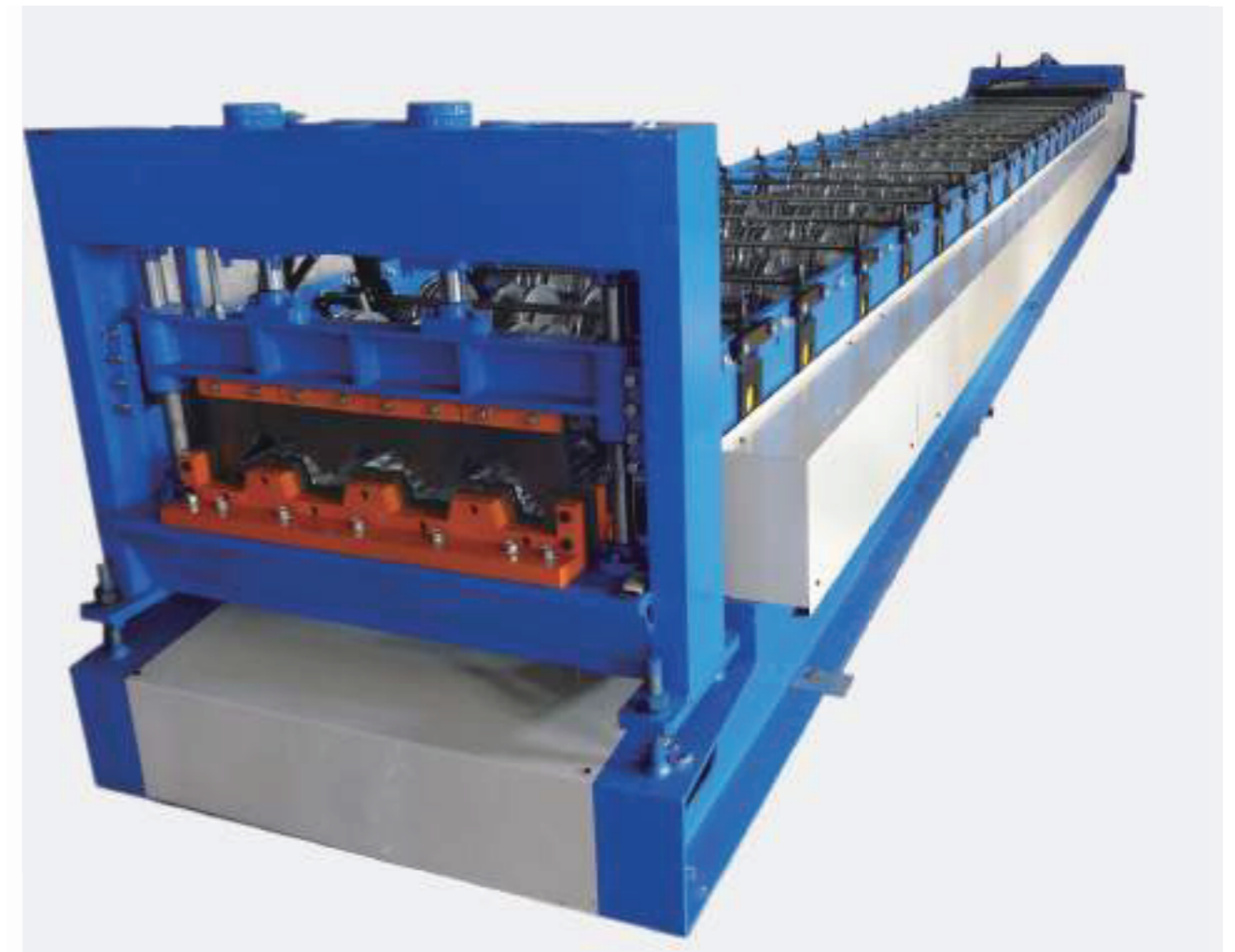

Profile Drawing(for reference only)

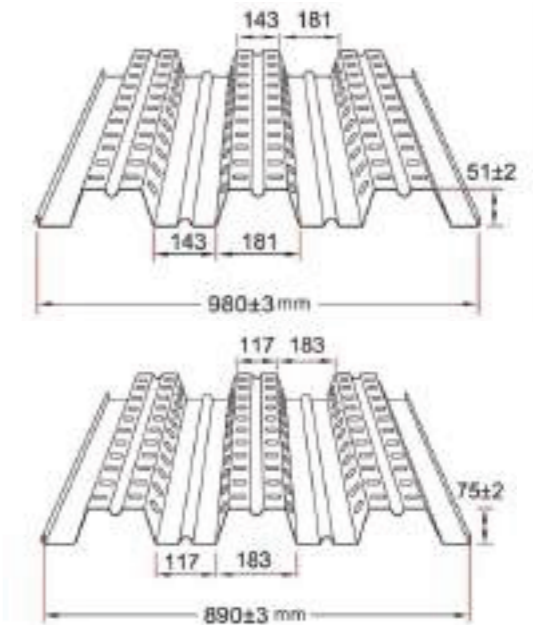

Pictures of Products

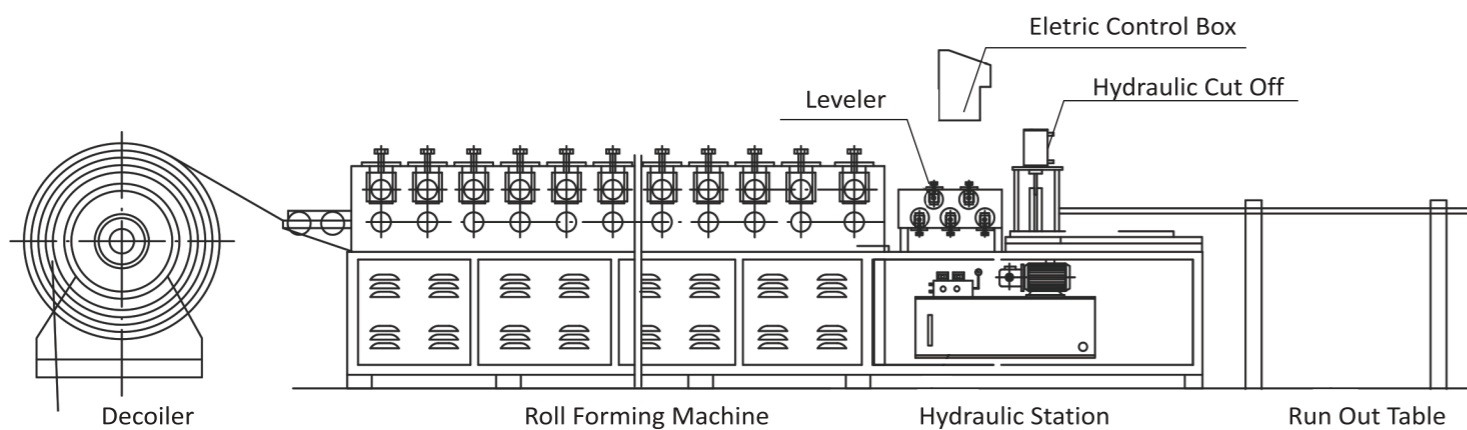

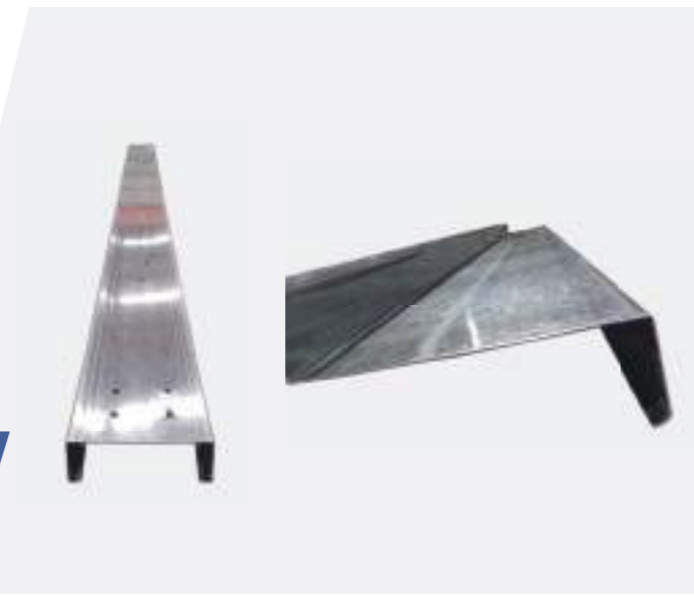

Pictures of Products

This machine is automatic size adjustable, setting by PLC.

Thickness: 1.5~3.0mm, 2.0~4.0mm
Web size: C100~300mm, Z120~300mm

Flange size ranges: C40~100mm, Z50~100mm
Lip size: 15~25mm

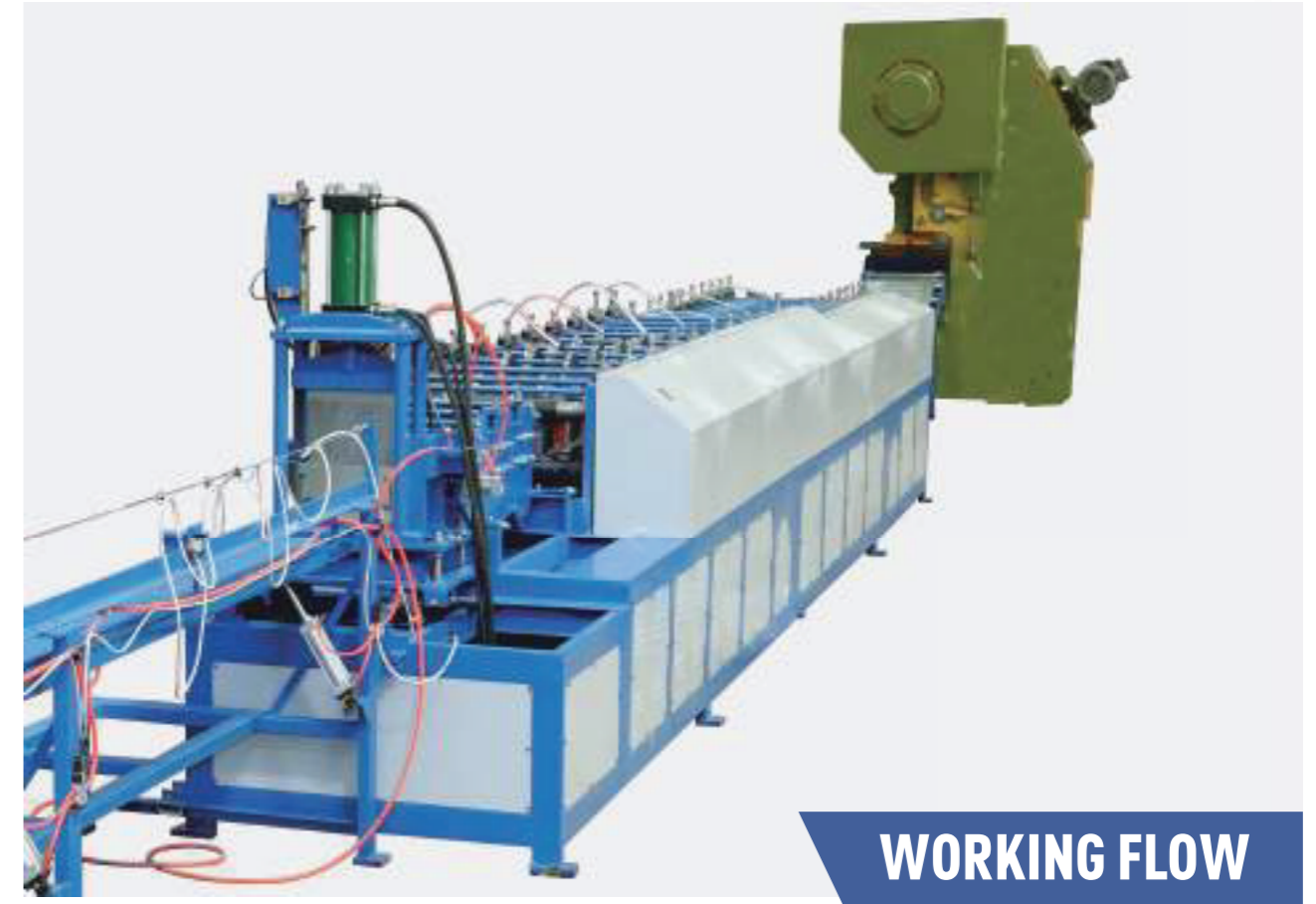

WORKING FLOW



Pictures of Products



Layout of the stainless tube roll forming machine

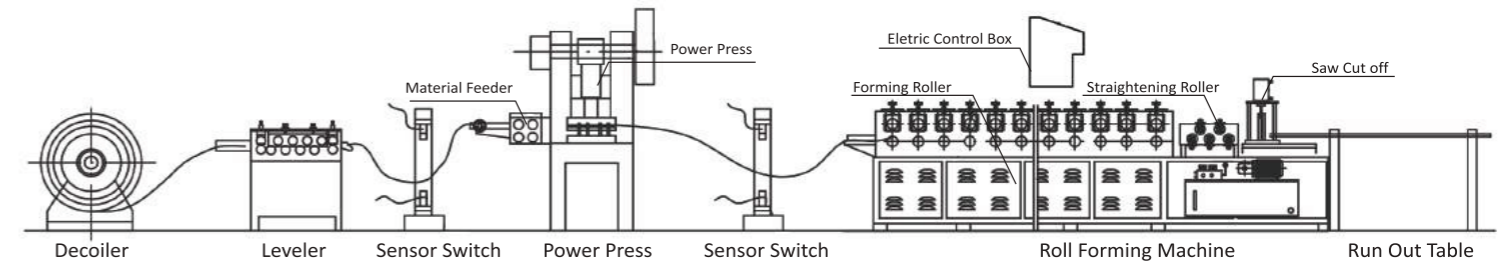



Pictures of Products



Profile Drawing(for reference only)

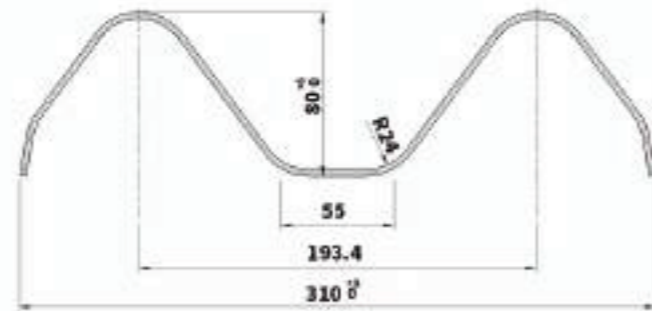

WORKING FLOW



Layout of the stainless tube roll forming machine

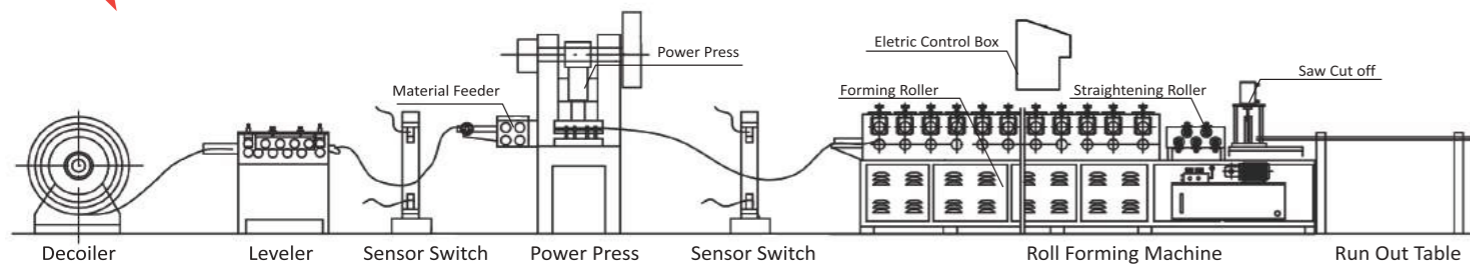

Pictures of Products

